

# TWINQO

Phil Home Automation Services

## Automated Gate

CCTV . ELECTRIC FENCE



Unit R1 Deguzman Compound Brgy Tagpos Binangonan Rizal



Facebook.com/twinqo.ph



account@twinqophil.com



+63995 679 0001 |



+63918 384 9972

# TWINQO

## Automated Gate

CCTV . ELECTRIC FENCE

<https://twinqophil.com>

We are proud to have become the premier source of quality gate access products.

We specialize in making and installing electric automatic gates. We are a team of experienced electricians and installers, with commitment to providing quality workmanship. Right from the outset we take the time to ensure that the automatic gate solution is ideal for your particular premises and requirements.

We'll even help you with your warranties from products you may have once purchased from another distributor. So, when your gate breaks, you don't need to worry about having to wait for the warrantied parts to come in, because we usually have them in stock. That's because we believe in exceptional customer service, so we give you the part you need and then wait for the warrantied part to be sent to us by the manufacturer. We think that when it comes to making a choice about who has to wait for parts, we'd rather do the waiting for our customers. That way our customer's gate access systems can be operational as quickly as possible.



# Our Products

- Modern gate manufacturing
- Swing Gate Opener
- Sliding Gate Opener
- Automatic Sliding Door System
- Interior Swing Door Opener
- Automatic Window Opener
- Automatic Curtain Opening
- Solar Gate and Window System
- (CCTV) Surveillance Camera
- RFID and Biometric Access Control
- Boom Barrier and Parking System
- Electric Fence

**OUR TEAM**

## We Supply | Design | Install and Consulation



Surveillance (CCTV)

Access Control  
Biometric Time Attendance

Home & Business  
Alarm System

Fire Alarm System

Security Products

Walkthru metal detector

Guard Tour System

Garrett & Super Scanner  
Metal Detectors

Crown SR  
Mega Phone

Turnstile System  
RFID / Access Control

Boom Barrier

Wired & Wireless System

High-gain 150M Wireless  
Outdoor Access Point(302.11 Mbps)

Internet

Wireless AP mode

PC with Wireless Card

Web Pn

Wired Pn

Solution for Office, Home, Security, Business

PABX|IPBX

[facebook.com/twingo.ph](https://facebook.com/twingo.ph)

# DESIGN AND INSTALLATION Advanced Surveillance System

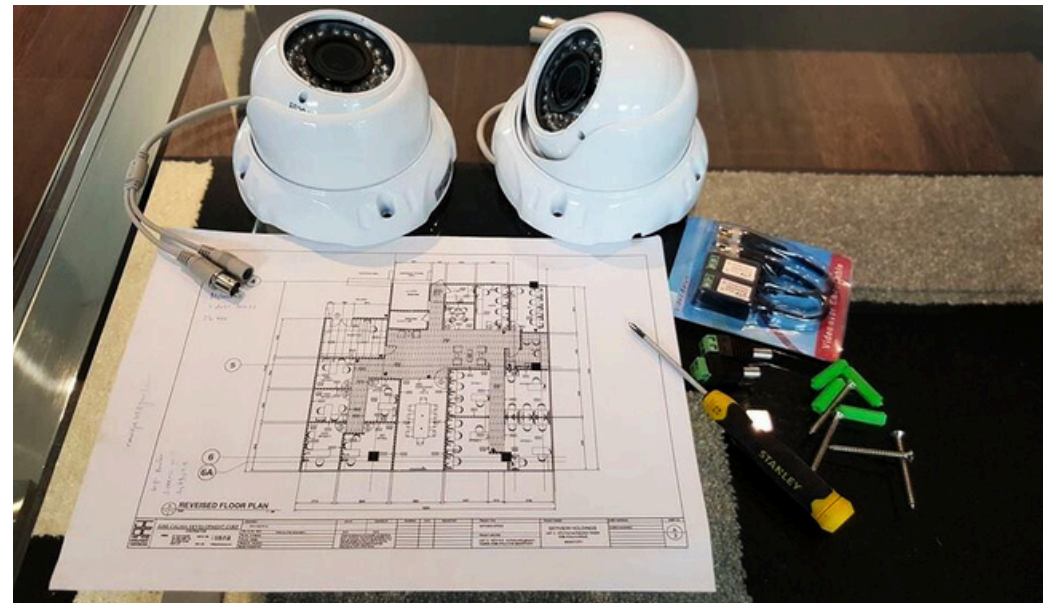

At Automated Gate Supply, our goal is to do whatever it takes to help you grow your business. Whether you need us to help you with product research, or assist you with warranties, we're here to serve you. We know that time is of the essence, so if you find yourself in a time crunch, we have a driver and a delivery truck ready to take your order to your office, or job site. We want to thank you for all your support throughout the years and plan to serve you for many more to come!



# Swing and Bifold Gate Fabrication

Motor: 24VDC motor with mechanical release

Gear type: Worm gear

Max absorbed power: 144W

Peak thrust: 3500N

Nominal thrust: 3000N

Stroke length: 300mm

Power supply: 24VDC

Nominal input power: 2A

Maximum operating current: 5.5A for maximum 10 seconds

Maximum gate weight: 500kg per leaf

Maximum gate length: 3meters

Duty cycle: 20%



ios 

## Why Choose Us!

### Your Team of Gate Specialists

At Automated Gates and Equipment we know that it takes more than just the right machinery - it takes craftsmanship

### A Dependable Company You can Count on for Your Security

Your security needs are important and deserve the attention of an experienced, dedicated team of access control specialists.

### Dedicated to Your Satisfaction Guaranteed

You can rely on Automated Gates and Equipment to be here for you long after your system is installed. All of our work carries a 100% satisfaction guarantee. In addition, many of our products carry warranties.



# Heavy Weight Sliding Gate Opener

## PSA1500

Material : Aluminium alloy

tVolt : AC 230V; 50Hz

Max. Gate Weight : 1500kg per leaf

Max. Gate Length : 12.0 meters per leaf

Gear Type : Worm gear

Dimension(mm : 250 x 174 x 323

Power: 425W

Manual Release : Key



Supply and installation  
of automatic sliding glass door

### Technical data

Door form: single door/double door

Loading weight:  $\leq 1 \times 150\text{kg} / \leq 2 \times 125\text{kg}$

Door width: 750-1600mm/650-1250mm

Power supply: AC220V, 50Hz

Rated Power : 65W

Opening speed: 150-460mm/S (adjustable)

Closing speed: 130-460mm/S (adjustable)

Open time: 0-8S (adjustable)

Temperature range:  $-20 \sim +50^{\circ}\text{C}$

Humidity range: <relative humidity 85%

Automatic Sliding Glass Door

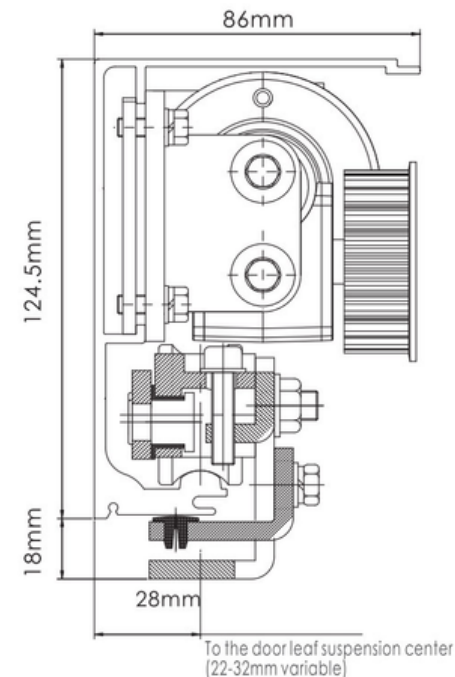

Adopting European motor and gearbox integration technology, the drive is strong, the operation is stable, the output power is improved, and it can adapt to the needs of larger doors.



## Residential Fence System

Aluminum , Galvanized,  
Stainless,  
Fiber Cement, WCP

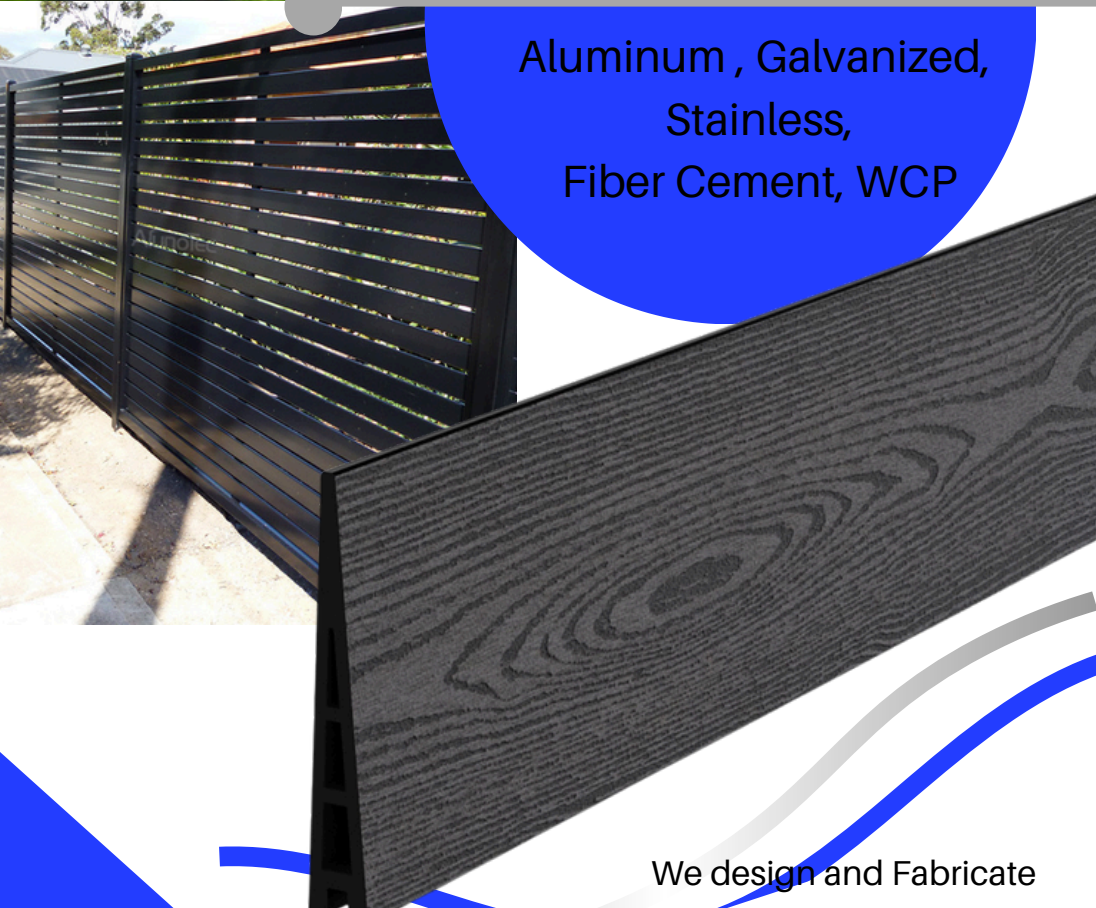

We design and Fabricate

# 1000kg Sliding Gate

Flexible application perfectly fits any  
entrance



high-performance sliding gate opener, featuring a control board with adjustable speed /force output/two photocell terminals/, for gates up to 1000kgs in weight and 12m in length.

**AC 230V / 110V; 50Hz~60Hz**

**Motor Volt : DC 24V**

**Max. Gate Weight : 1000kg per leaf**

**Max. Gate Length : 12.0 meters per leaf**

**Gear Type : Worm gear**

**Dimension (mm) : 333 x 216 x 287**

**Power : 144W**

**Manual Release : key**

We design and Fabricate

# Telescopic Sliding Gate Mechanism

Kit components:

Stainless Steel Rope, 4 pcs Connect Bracket with Bolts and pulley

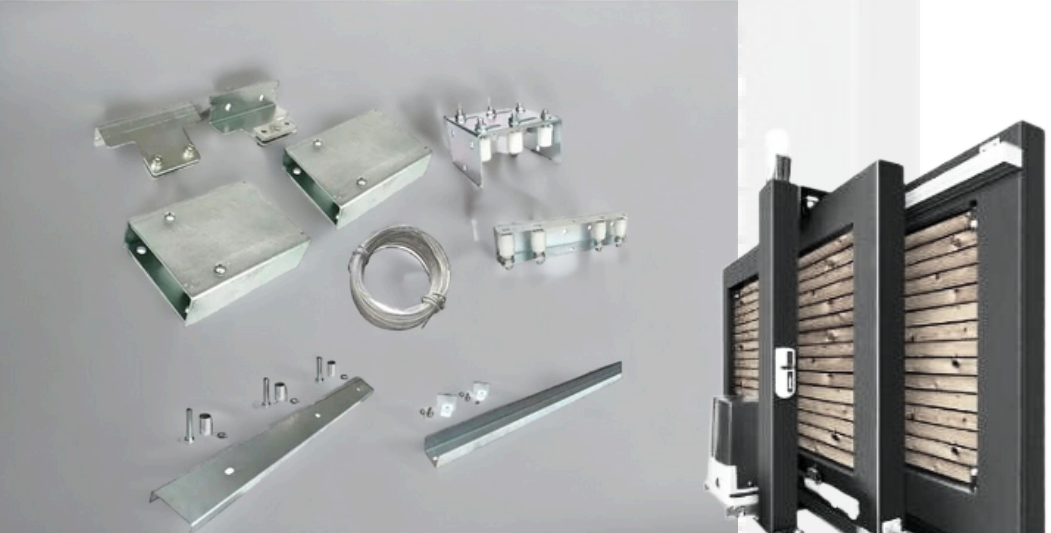

# Sectional Gate



**garage door opener has the round design. It can be installed in any scenario. We offer a variety of chain/belt rails available in the various lengths.**

**Supply: AC 220V / 110V; 50Hz~60Hz**

**Motor Volt : DC 24V**

**Power : 72W**

**Max Door Area : 8-10m<sup>2</sup>**

**Gear Type : Worm gear**

**Dimension (mm) : 360 x 228 x 115**

**Manual Release : Pull to Release**

**Running Speed : 14cm/sec**





**Timeout Alarm :yes**

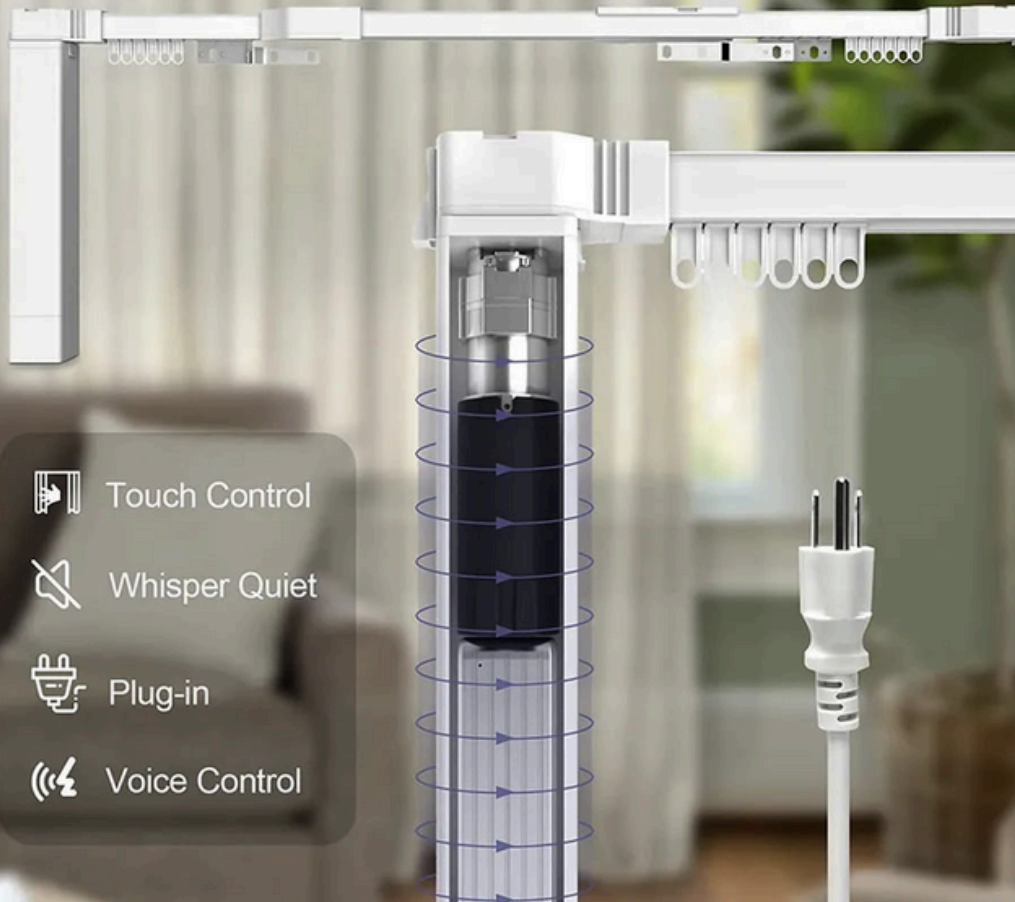

**We design and Fabricate**

## INTELLIGENT MOTORIZED CURTAIN MOTOR



-  Touch Control
-  Whisper Quiet
-  Plug-in
-  Voice Control



## 3 Tons Sliding Gate Industrial Sliding Gate Opener

ZT-3000  
220VAC/ 3000kg Sliding Gate Opener

- 1\*Sliding Gate Motor
- 1\* control board ,
- 2\* remote control
- 1\*Handle Hardware Accessories
- 1\*user manual

### SPECIFICATION

Item No.	ZT-3000	
Input Voltage	220V/50Hz	
Motor speed	1400r/min	
Output torque	170N.m	
Motor power	1000W	
Max gate weight	3000kg	
Gate speed	11m/min	
Limit switch	Spring/Magnetic	NO/NC
Temperature	-45°C ~ +65°C	
Noise	≤58dB	
Gear teeth	23T	



Twingo Phil Home Automation  
Services

# Wireless Video DOORBELL / Video Door Phone



2-wire digital IP video intercom kit for villa or house, only one call button

DS-KD8003-IME2/Surface x1

DS-KH6320-WTE2 x1

DS-KAD704 x1

DS-KAW30-2N x1

16GB TF card x1

 android **iOS**



Accessible via mobile app can be integrate to your automatic door locks



# Electric Fence Installation



## TH-Steward + WIFI

- OUTPUT PEAK VOLTAGE: 2KV to 10KV (ADJUSTABLE)
- PULSE DURATION: <0.1
- Remote control (wireless) makes the arming or disarming easily from any place.





# PREVENTIVE MAINTENANCE SERVICE

TWINQO PHIL is excited to announce The Shield Preventive Maintenance Program. This program is for homeowners and companies that wish to protect their assets, additions, and major property investments.

The purpose of this program is to establish consistent, scheduled maintenance for gates, Automation Mechanism and access control systems, Clients that invest in a preventive maintenance program benefit from enhanced reliability and extended product life span.

The Shield Preventive Maintenance (PM) Program has been designed for early detection of possible malfunctions and to reduce the potential downtime of a system that is expected to work 24/365.

This early detection prevents unwanted concerns about an unsecured home and reduces the security expenses of an unsecured facility.

---

## Summary Benefits

---

- **Support Priority Serve (Onsite Support Within 48hrs)**
- **B-new Replacement Serve**
- **Quarterly Maintenance Serve**
- **Exclusive Discount Serve**
- **Documented maintenance**
- **Identification of problems and repair before failure occurs**
- **Less costly downtime with an efficient system**
- **The prolonged operating life of your system**
- **Fast, reliable and professional service**

## What checks are carried out by gate maintenance engineers?

- Check overall system
- Force testing
- Check alignment of hinges
- Check gate for any structural issues on frame
- Inspect the gate whilst opening/closing
- Full safety inspection checking photocells are aligned, safety edges are fully operating and the gate stops and returns on impact
- Inspect for any oil leaks
- Lubricate all mechanical parts
- Lubricate hinges and pins
- Check gate automation settings: speed, slow down upon opening and/or closing
- Check manual release in case of power failure
- Inspect earth cables and any other visible cable within and around the motor
- Check access keys and key fobs
- Check intercom systems
- Inspect general overall condition of the gate



+63995 679 0001

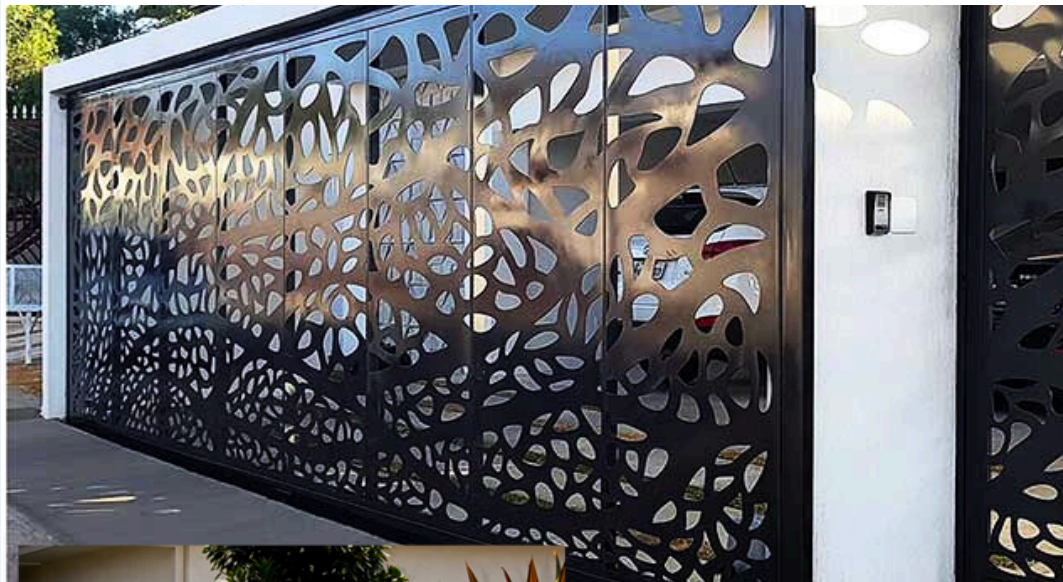

### LGA-03 Bifold gate

Aluminum Laser Cut pattern

Materials :

- \*Aluminum Sheet
- \*Aluminum Tubular frame
- \*Powder coated paint finish
- \*Laser Cut Pattern
- \*Automated Gate
- \*Trackless Folding Gate

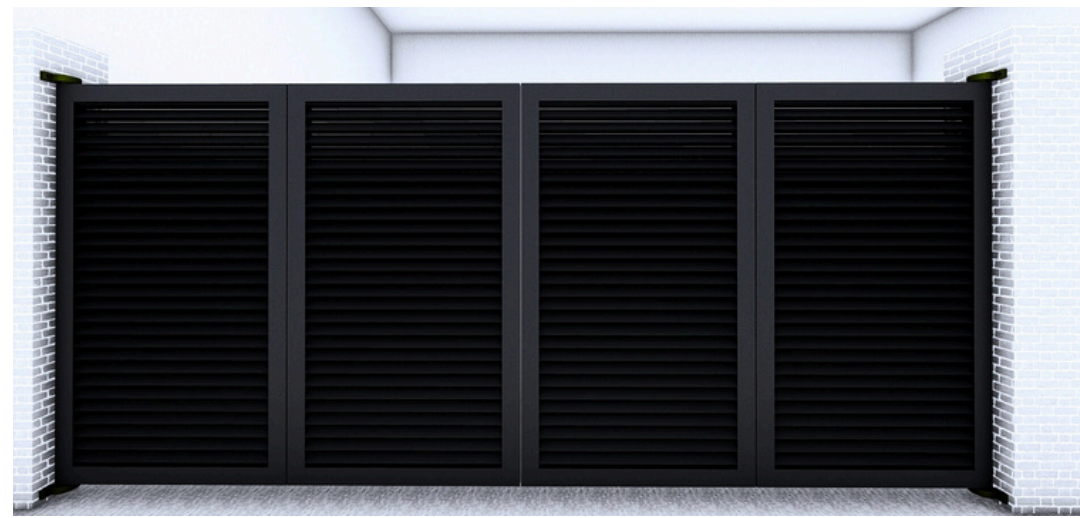

### LGA-04 Bifold gate

Aluminum Louver Gate

Materials :

- \*Aluminum Tubular
- \*Aluminum Tubular frame
- \*Powder coated paint finish
- \*Automated Gate
- \*Trackless Folding Gate

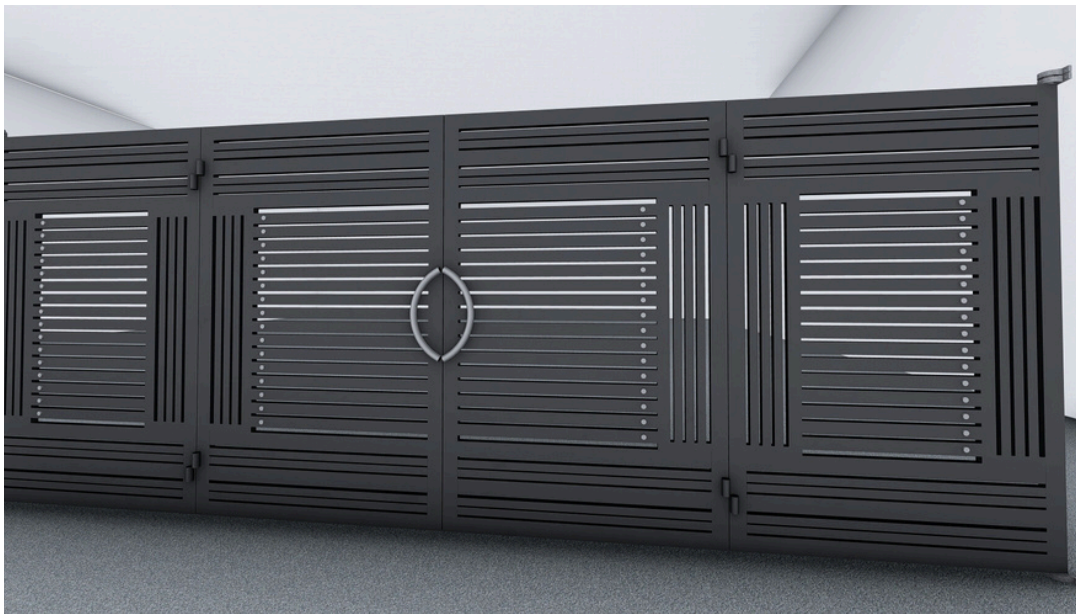

### LGA-04 Bifold gate

Aluminum Heavy Duty Modern Gate

Materials :

- \*Aluminum Tubular
- \*Aluminum Tubular frame
- \*Powder coated paint finish
- \*Automated Gate
- \*Trackless Folding Gate

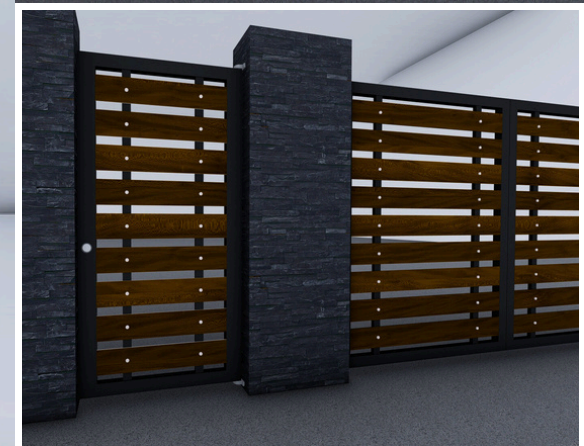
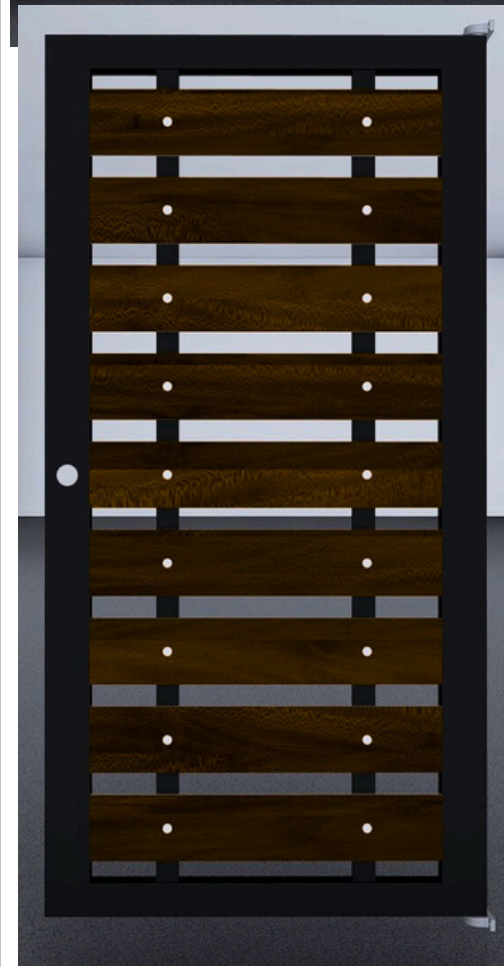

### LGA-05 Bifold gate

Aluminum with Fiber Cement

Materials :

- \*Aluminum Tubular
- \*Aluminum Tubular frame
- \*Fiber Cement
- \*Powder coated paint finish
- \*Automated Gate
- \*Trackless Folding Gate

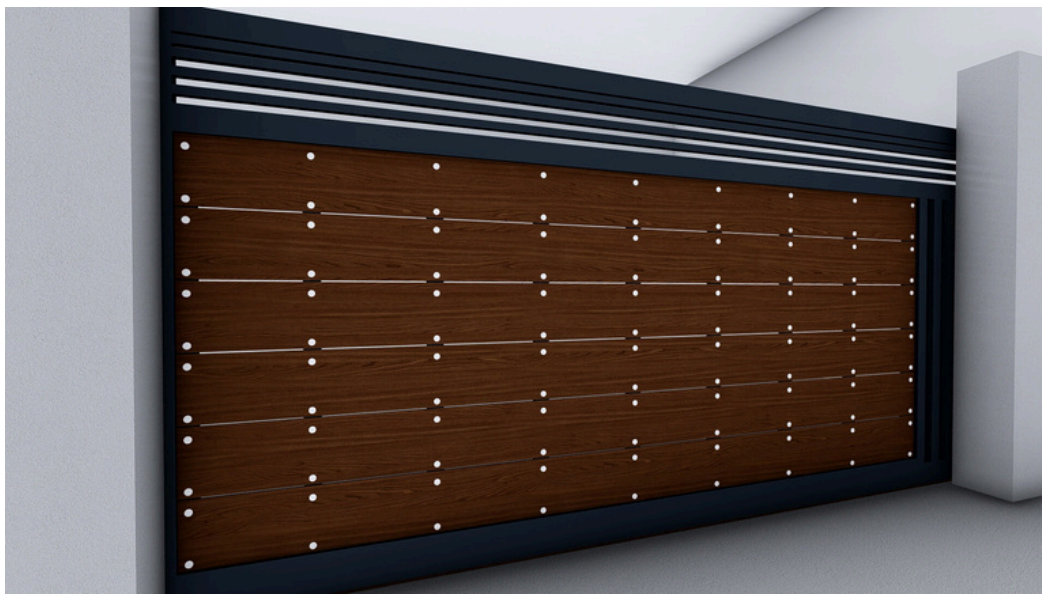

### LGA-06 Sliding gate

Aluminum Heavy Duty Modern Gate

Materials :

- \*Aluminum Tubular
- \*Aluminum Tubular frame
- \*Powder coated paint finish
- \*Fiber Cement Board
- \*Automated Gate
- \*Trackless Folding Gate

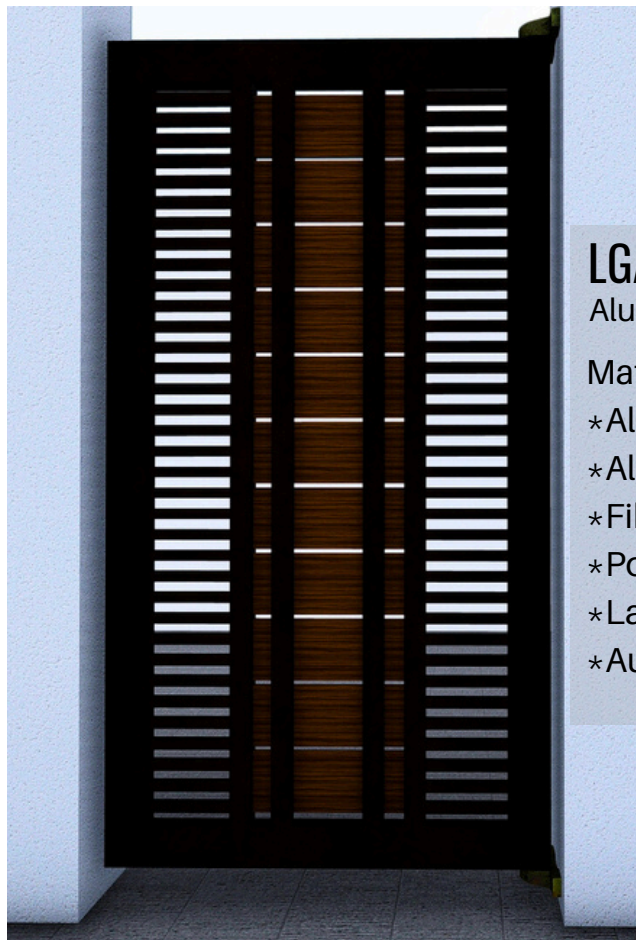

### LGA-07 Swing gate

Aluminum / Fiber Cement

Materials :

- \*Aluminum Tubular
- \*Aluminum Tubular frame
- \*Fiber Cement
- \*Powder coated paint finish
- \*Laser Cut Pattern
- \*Automated Gate



## Automatic Sliding Glass Door

## Technical data



Door form: single door/double door

Loading weight:  $\leq 1 \times 150\text{kg} / \leq 2 \times 125\text{kg}$

Door width: 750-1600mm/650-1250mm

Power supply: AC220V, 50Hz

Rated Power : 65W

Opening speed: 150-460mm/S (adjustable)

Closing speed: 130-460mm/S (adjustable)

Open time: 0-8S (adjustable)

Temperature range:  $-20 \sim +50^{\circ}\text{C}$

Humidity range: <relative humidity 85%